

# PIR Sensor Stair Light Controller

- Multifunctional PIR sensor stair light controller features daylight sensor, 2 groups different SPI(TTL) signal output.
- Group 1 SPI signal output to realize white light step or color light step control.  
Default is white light step control, use with ES-F step sub-controller to realize the step control of each step white light strip.
- Group 2 SPI signal output for color light flow control.
- Color light step or color light flow output, can drive 18 kinds of IC digital RGB LED strip, can set IC type and R/G/B order.  
Compatible ICs: TM1804, TM1812, UCS1903, UCS1909, UCS1912, UCS2903, UCS2909, UCS2912, WS2811, WS2812, TM1829, TM1914A, GW6205, GS8206, UCS5603, UCS2603, SM16714D, SM16703P.
- Easy operation with OLED display and 3 buttons.
- Built-in multiple color mode, speed and brightness 1-8 grade adjustable.
- Use with two PIR body sensor heads (standard), or when precise sensing is required, the optional infrared reflector kit ES-T is available.



PIR sensor / Daylight Sensor / 24 steps/Compatible with 18 kinds of chips/ Max 720 pixels/ OLED display / Motion sensor

## Technical Parameters

ES24 master parameters		ES-F step sub-controller parameters		Safety and EMC	
Input voltage	5-24VDC	Input voltage	5-24VDC	EMC standard (EMC)	ETSI EN 301 489-1 V2.2.3 ETSI EN 301 489-17 V3.2.4
Input current	20A	Output voltage	5-24VDC	Safety standard(LVD)	EN 62368-1:2020+A11:2020
Output power	100-480W	Output current	Max 1A	Certification	CE, EMC
Output type	2 x SPI(TTL)	Input signal	SPI(TTL)	<b>Environment</b>	
Number of steps	Default 24, Max 72	<b>Package</b>		Operation temperature	Ta: -30°C ~ +55°C
Stream pixel count	Max 720	Size	L192 x W153 x H55mm	Case temperature(Max.)	Tc: +85°C
<b>Sensor data</b>		Gross weight	1.52kg	IP rating	IP20
Sensing range	≤3m	<b>Warranty</b>			
Sensitivity angle	30°(±10°)	Warranty	5 years		

## Mechanical Structures and Installations

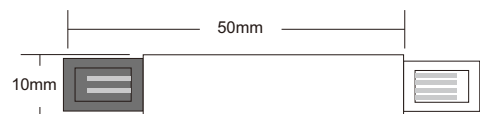
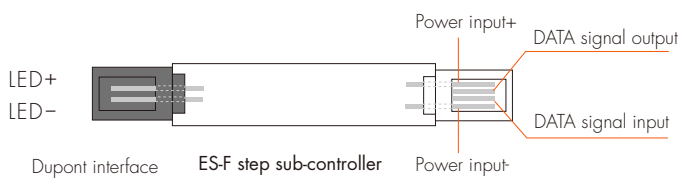
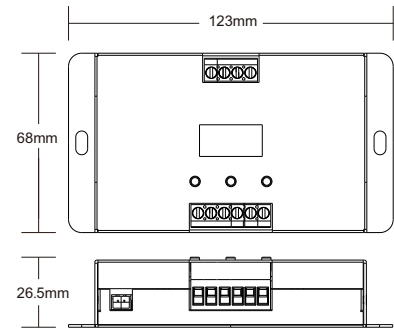
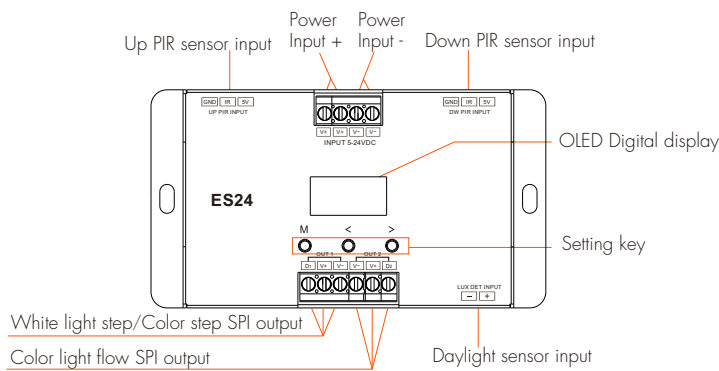

# Wiring Diagram

## 1. White light step + Color light flow

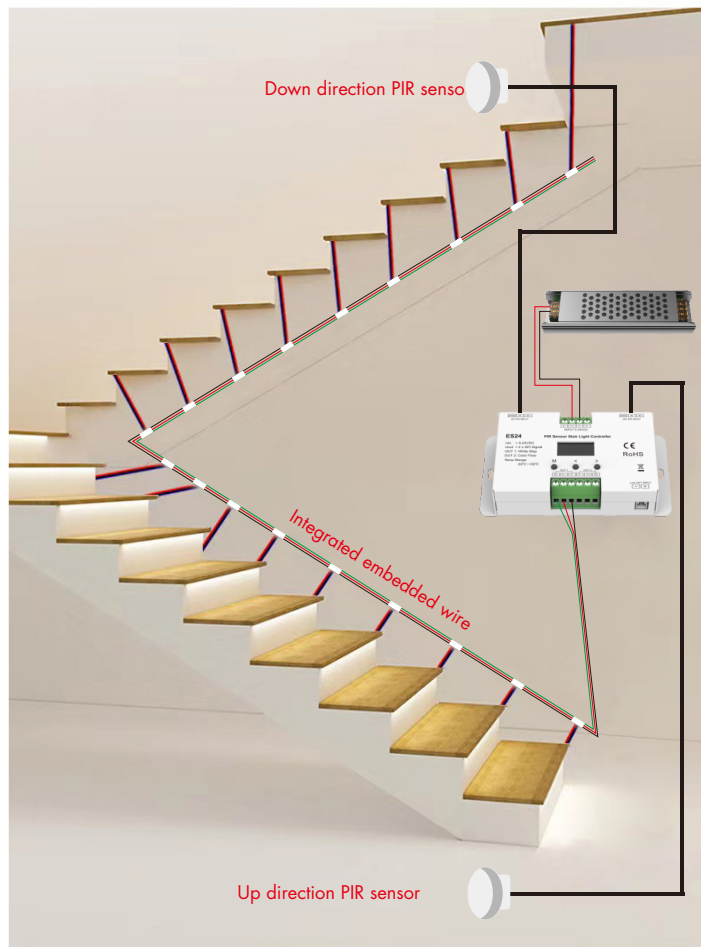
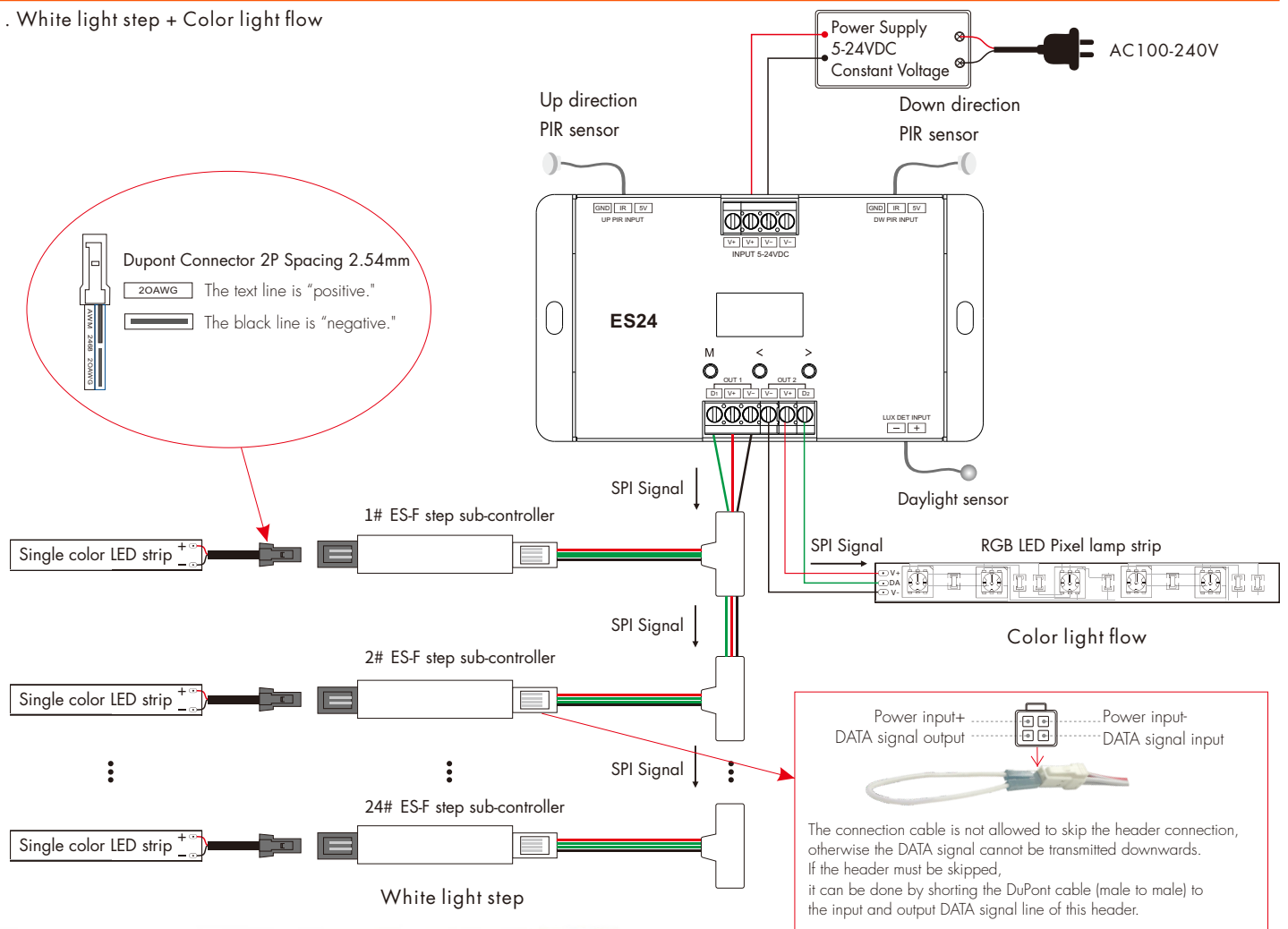

(White light step stairs connection schematic)

### Note:

1. When the SPI strip load does not exceed 20A, the same power supply can simultaneously power the ES24 master and the SPI strip at the same time. When the load on the SPI strip exceeds 20A, separate power supplies are required for the ES24 master and the SPI strip. Only DATA and GND signal lines are connected between ES24 master and SPI strip.
2. The PIR sensor can be replaced with a stair infrared reflection sensor (ES-T) or other sensors that output 5V level signals.
3. The white light step must be used with ES-F step sub-controller and select ES-F in the system parameter interface "CH1".
4. The white light step defaults to 24 steps and comes standard with one 24-connector SPI cable. The white light step can be set up to 72 steps, which means that three 24-connector SPI connection cables are required, and connects 72 ES-F step controllers.
5. The color light step needs to select the chip type such as TM1809 in the system parameter interface "CH1".
6. The color light step defaults to 24 steps with 10 pixels per step. The maximum number of colored steps is 72, and the maximum number of pixels per step is 90.
7. The color light flow can control up to 720 pixel points of SPI strip.

## 2. Color light step + Color light flow

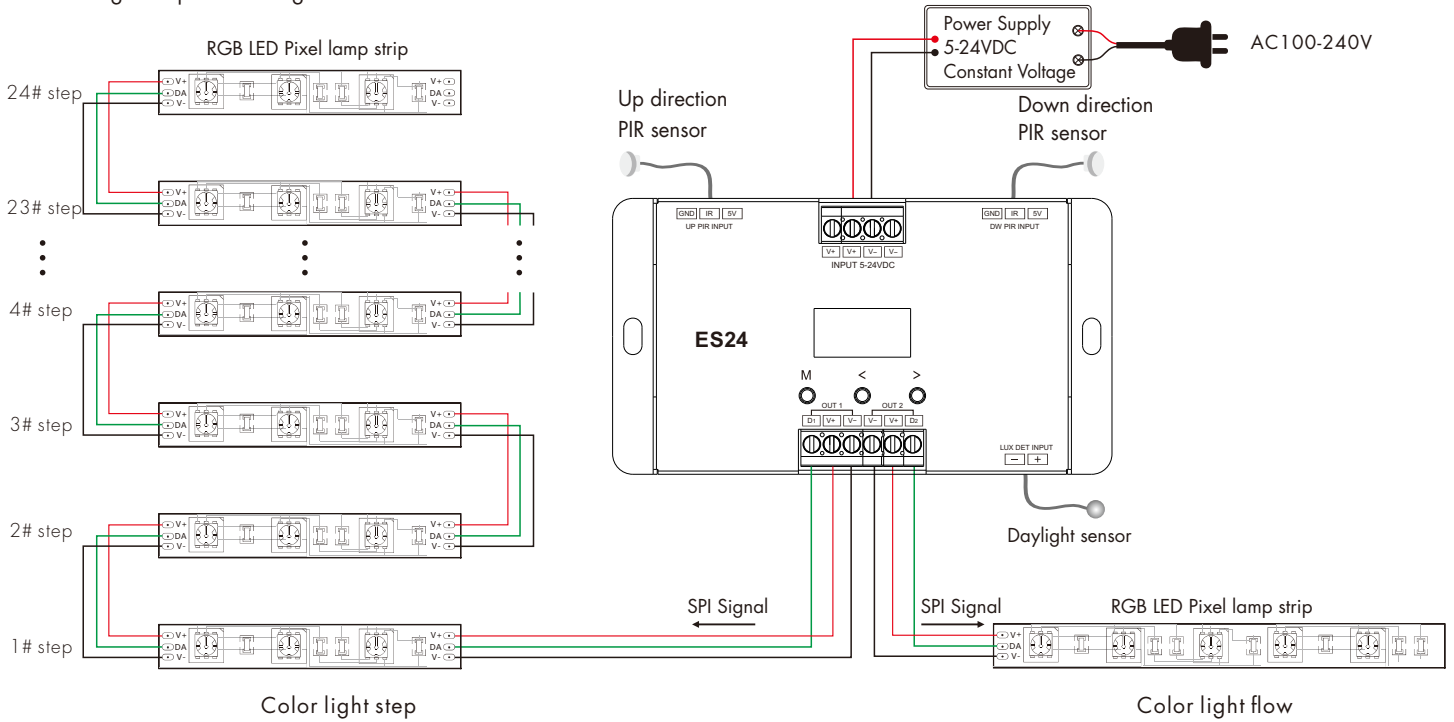

## OLED screen and key operations

1. Long press M key for 2s, enter system parameters setting state, set chip type and RGB order for group 1 and group 2 SPI output signals, custom RGB color, the daylight sensor threshold, and turn off light delay time.
2. Short press M key, enter the operation parameter setting status, including step number, pixel point number, color mode, brightness and speed level.
3. When in parameters setting state, short press M key to switch multiple parameters, press < or > key for parameters' adjustment.
4. Long press M key or wait 15s to quit parameter setting state.
5. Long press M & > key for 2s, display "Light up test" on the 4 line, start up direction induction light testing.
6. Long press M & < key for 2s, display "Light down test" on the 4 line, start down direction induction light testing.
7. Long press < & > key for 2s, restore factory default parameters, jump to language interface automatically, press < or > to switch two languages (Chinese and English), press M key to exit language interface.
8. The 4 line display color mode name defaultly.

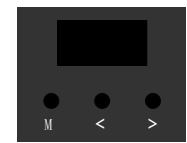

OLED screen and buttons



Language interface

When the controller is in induction state, the indication of inductive signal input ("Light up start" and "Light down start") is displayed first, and then the light on/off status is displayed.  
If the current detected LUX value is greater than daylight sensor threshold, display "Light up off" or "Light down off" on the 4 line.

## Main interface

**Step:** Set the number of steps of white light step or color light step.

- Number of white light steps, 08-072.
- Number of color light steps, 08-072; Pixel dot number of each step, 01-90.

The Step number x Dot number must < 720.

For example, to display 2410, 24 indicates the number of steps and 10 indicates the length of pixel dots per step.

**Dot:** Total number pixels of color light flow, 024-720.

**I/O:** Turn on/off light mode, that is, sequential or simultaneous on/off light, a total of four options.

White/color light step and color light flow using the same on/off light mode.

**Mode:** Color mode number, 01-12,

Color light step and color light flow use the same mode number.

**Bright:** Brightness level, 1-8, 8 is the maximum brightness.

The same brightness level is used for white/color light step and color light flow.

**Speed:** Speed level, 1-8, 8 is the fastest speed.

The same speed level is used for white/color light step and color light flow.

### Inductive on/off light methods list:

Display	Name
s I s 0	Turn on and turn off lights in sequence
s I c 0	Turn on the lights in sequence and turn off the lights at the same time
c I s 0	Turn on the lights at the same time and turn off the lights in sequence
c I c 0	Turn on and turn off lights at the same time

```
Step:24 Dot:300
I/O:sIs0 Mode:01
Bright:8 Speed:8
*****
```

White light step + Color light flow  
(Light on/off state on 4 line)

```
Step:2410Dot:300
I/O:sIs0 Mode:01
Bright:8 Speed:8
Light up start
```

Color light step + Color light flow  
(Inductive indication on 4 line)

### Color light step / Color light flow mode list:

No.	Name
01	Red
02	Orange
03	Yellow
04	Green
05	Cyan
06	Blue
07	Purple
08	White
09	Color queue ( 7 color + White)
10	Color chase( 7 color + White)
11	Color fade (6 color flow)
12	Rxxx Gxxx Bxxx (User define)

## System parameters setting

**CH1:** White light step select ES-F (step sub-controller).

Color light step select a variety of chips (TM1809, etc.), and six RGB sequences (RGB, RBG, GRB, GBR, BRG, BGR) can be selected.

**CH2:** Color light flow select a variety of chips (TM1809, etc.) and six RGB sequences (RGB, RBG, GRB, GBR, BRG, BGR) can be selected.

Different chip types are available for color light step and color light flow.

Digital pixel RGB LED strip compatible IC types list:

IC type	Compatible IC type
TM1809	TM1804, TM1812, UCS1903, UCS1909, UCS1912, UCS2903, UCS2909, UCS2912, WS2811, WS2812, SM16703P
TM1829	
TM1914A	
GW6205	
GS8206	GS8208
UCS5603	
UCS2603	
SM16714D	

```
CH1: ES-F
CH2: TM1809 RGB
DefRGB: FF FF 80
LuxSet : OFF *050
```

System parameter setting page 1

**Def RGB:** RGB hex value for user-define color. The parameters are valid for color light step or color light flow.

**LuxSet:** Set the daylight sensor threshold (10, 30, 50, 100, 150, 200, OFF).

With sufficient ambient light, the PIR sensor does not turn on the light. Daylight sensor default off.

The digital value after \* is current detected LUX value.

**OFF delay:** Set turn off light delay time (5sec, 10sec, 15sec, 20sec, 30sec, 1min, 3min, 5min, 10min, Cancel), default 10sec.

```
OFF delay:10sec
```

System parameter setting page 2

## Installation of PIR sensor

Size of detector:

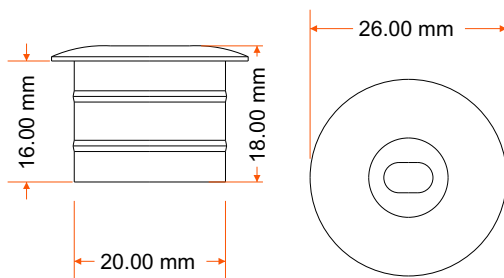

PIR sensor detection scope ( $\pm 10^\circ$  Error):

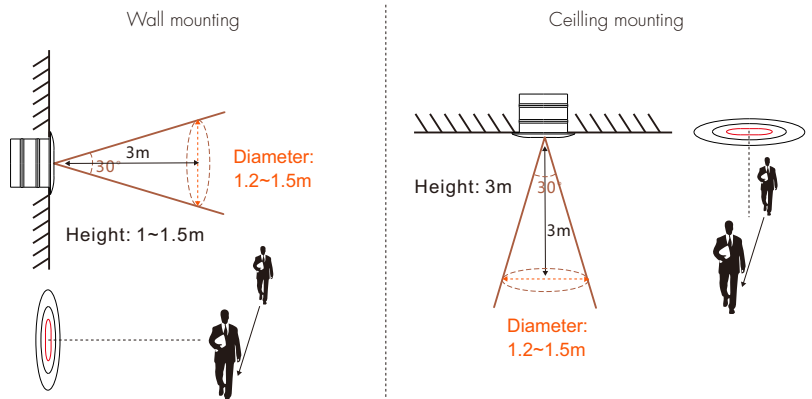

Notice for installation of PIR sensor

1. Recommended for wall mounting.
2. If the sensor is exposed to direct sunlight, interference signal will be introduced.
3. The sensor should be installed in a dry environment and keep away from windows, air conditioner and fans.
4. Make sure that the sensor stays away from heat source, such as countertops, kitchen appliances which generate hot steam, walls and windows in direct sunlight, air conditioner, heating, refrigerators, stoves and so on.
5. We recommended the wall-mounted installation height is 1-1.5 meters and the ceiling mounting height is no more than 3 meters.
6. There should not be shelter (screen, furniture, large bonsai) within the range of detection.

★ For wall mounting and ceiling mounting, note that the sensing holes are perpendicular to the direction of human movement.

## Packing List



LED Controller  
1 pcs



User Manual  
1 pcs



Daylight sensor  
(30cm)  
1 pcs



ES-F  
24 pcs



PIR sensor  
(1.2m)  
2 pcs



PIR sensor  
extension line  
(5 m)  
2 pcs



ES-F connection line  
(11m)  
(24 interfaces)  
1 pcs