

# F1-M(WT)+RC1

## WiFi & Infrared remote LED Dimmer

- WiFi & Infrared remote control 1 channels constant voltage single color LED dimmer.
- DC power socket input, 5A output, output connects with 5 meters RGB LED strip.
- Tuya Smart APP cloud control, support on/off, brightness adjust, delay turn on/off light, timer run, scene edit function.
- Voice control, support for Amazon Alexa, Google Assistant, Tmall Genie and Xiaodu voice assistant.
- Adjust the brightness by IR remote or SET key.
- 4096 levels dimming smoothly without any flash.
- Logarithmic dimming curve.



CE RoHS 

### Technical Parameters

Input and Output	Dimming data	Safety and EMC
Input voltage	Input signal	EMC standard (EMC)
5-24VDC	WiFi + IR + key	ETSI EN 301 489-1 V2.2.3 ETSI EN 301 489-17 V3.2.4
Output voltage	Control distance	Safety standard
5-24VDC	10m(Barrier-free space)	EN 61348-1:2015+A1:2021 EN 61348-2-13:2014+A1:2017
Output current	Dimming gray scale	Certification
Max. 5A	4096 level	CE, EMC
Output power	Dimming range	
25W@5V 60W@12V 120W@24V	10-100%	
	Dimming curve	
	Logarithmic	
Environment	PWM Frequency	Package
Operation temperature	2000Hz (default)	Size
Ta: -20°C ~ +50°C	Warranty	L110x W57x H32mm
Case temperature (Max.)	5 years	Gross weight
Tc: +85°C	Protection	0.090kg
	Over heat	

### Mechanical Structures and Installations

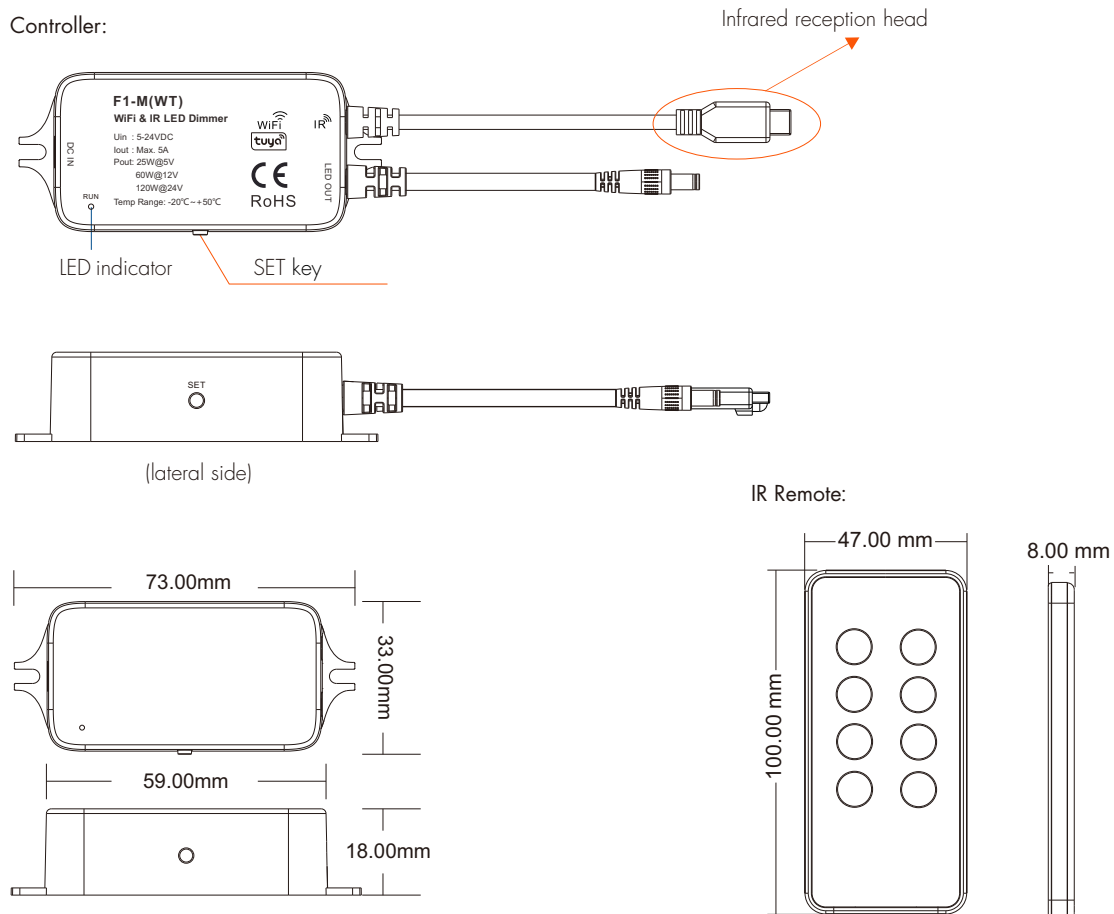

## Wiring Diagram

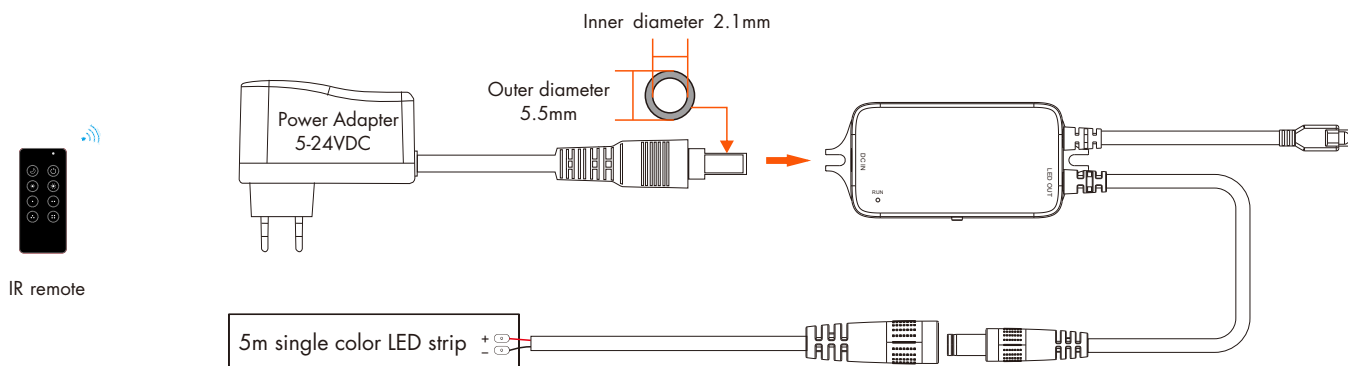

## System Wiring

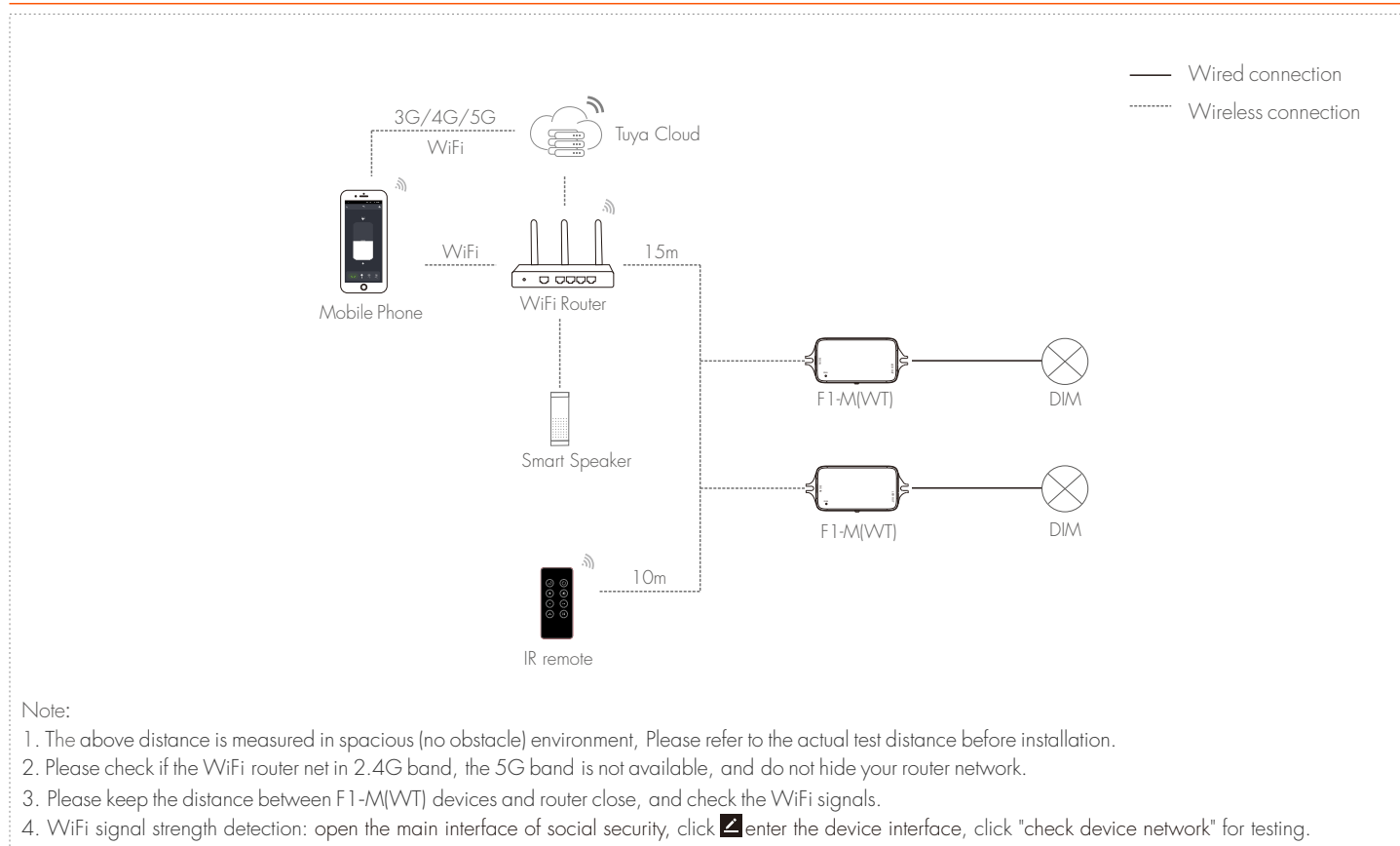

## Key Function of IR Remote

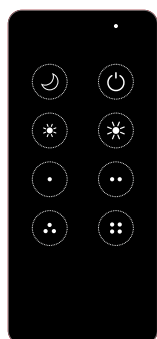

- : Short press turn on/off the light.
- : Night light function, 10% brightness with short press.
- : Increase brightness, Short press 10 levels, long press 1-6s for continuous 256 levels adjustment.
- : Decrease brightness, Short press 10 levels, long press 1-6s for continuous 256 levels adjustment.
- Short press to select each of the four brightness levels: 25%, 50%, 75%, 100%.

### Notes:

1. IR remote control does not need to be paired and can be controlled directly.
2. When the remote control is far away, using infrared remote control, you need to align with the infrared sensor head.

## SET Key Function of Dimmer

Short press: sequentially switch 5 levels of light brightness (10%, 25%, 50%, 75%, 100%).

Long press (1-6s): Step-less dimming, with every other long press, the light level goes to the opposite direction, dimming range 10%-100%.

## Tuya Smart APP Network Connection

Please download the corresponding Tuya Smart/Smart life APP according to your region.

Three methods to clear the previous network connection, enter WiFi Smart config mode, and the output LED will flash 10 times.

1. Long press the SET key for 12s.
2. Double click the SET key within 10s of the dimmer powering up.
3. Dimmer power on and off for 5 consecutive times.



Smart life APP



Tuya Smart APP

In Tuya Smart APP, you can find DIMc device.

If Tuya Smart APP network connection succeed, the output LED will stop flash.

## Tuya Smart APP Interface

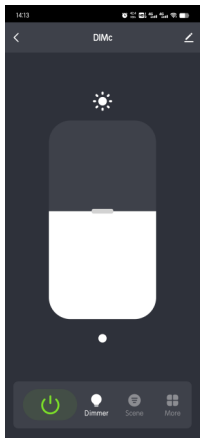

### White interface

Touch brightness slide to adjust brightness.

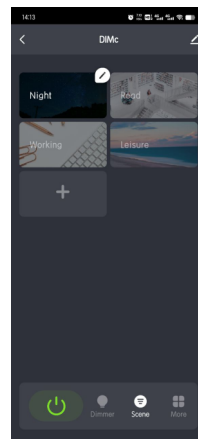

### Scene interface

The 1-4 scene is static color.  
the inner color of these scene can be editable.

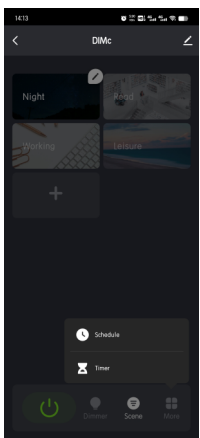

### Timer, Schedule

The Schedule key can add multiple timers to turn on or turn off light according to different time periods.

The Timer key can turn on or turn off light in the next 24 hours.

## Dimming Curve

