

Single Color LED Controller Kit

Model No.: V1 + RT1

1 channels constant voltage/Touch color wheel/Stepless dimming/Wireless remote 30m distance



Feature

- Remote control or connected with external push switch to achieve on/off and dimming function
- Ultra sensitive brightness adjustment touch wheel
- Smooth dimming and switch without any flickering
- 4 scene memory
- Auto-transmitting function: Controller automatically transmit signal to another controller with 30m control distance
- Light on/off fade time 3s selectable

Technical Parameters

LED Receiver's Input and Output	
Input voltage	5-36VDC
Input current	8.5A
Output voltage	5-36VDC
Output current	1CH, 8A
Output power	40W/96W/192W/288W (5V/12V/24V/36V)
Output type	Constant voltage

Dimming data	
Dimming level	4096 levels
Dimming range	0-100%
Dimming curve	Logarithmic
PWM Frequency	2000Hz

Warranty and Protection	
Warranty	5 years
Protection	Reverse Polarity

LED Remote's Input and Output	
Output signal	RF[2.4GHz]
Working voltage	3VDC(AAAx2)
Working current	< 5mA
Standby current	< 10µA
Standby time	2 year
Remote distance	30m

Safety and EMC	
EMC standard (EMC)	ETSI EN 301 489-1 V2.2.3 ETSI EN 301 489-17 V3.2.4
Safety standard(LVD)	EN 62368-1:2020+A11:2020
Radio Equipment(RED)	ETSI EN 300 328 V2.2.2
Certification	CE, EMC, LVD, RED

Environment	
Operation temperature	Ta: -30°C ~ +55°C
Case temperature (Max.)	Tc: +85°C
IP rating	IP20

Mechanical Structures and Installations

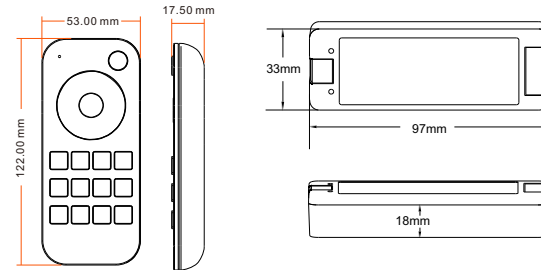
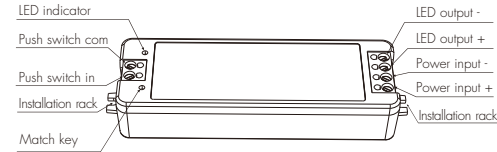

Wiring Diagram

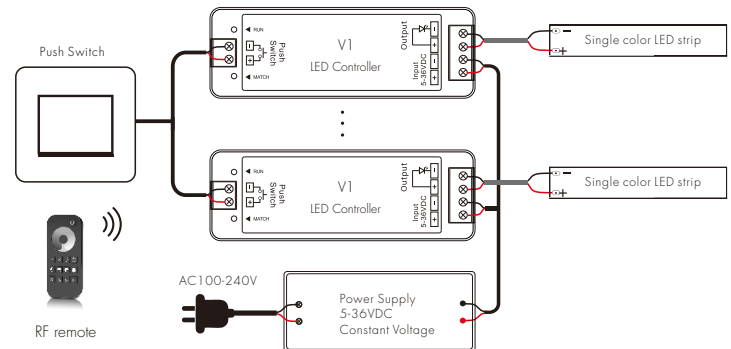

Remote function



- : Turn on/off light.
- : Touch to change brightness.
- : Adjust brightness, short press 10 levels, long press 1-6s for continuous 256 levels adjustment.
- : Small night brightness (10%).
- : Turn off light after 30s, long press 2s will turn off light after 60s.
- : 25%, 50%, 75%, 100% brightness.
- : Short press recall the scene, long press 2s save current brightness into S1/2/3/4, the LED indicator display green when save OK.

Match Remote Control (two match ways)

End user can choose the suitable match/delete ways. Two options are offered for selection:

Use the controller's Match key

Match:
Short press match key, immediately press on/off key of the remote.

Delete:
Press and hold match key for 5s to delete all match, The light blinks 5 times means all matched remotes were deleted.

Use Power Restart

Match:
Switch off the power, then switch on power, repeat again. Immediately short press on/off key 3 times on the remote. The light blinks 3 times means match is successful.

Delete:
Switch off the power, then switch on power, repeat again, Immediately short press on/off key 5 times on the remote. The light blinks 5 times means all matched remotes were deleted.

Light on/off fade time

Long press match key 5s, then short press match key 3 times, the light on/off time will be set to 3s, the indicator light blink 3 times.

Long press match key 10s, restore factory default parameter, the light on/off time also restore to 0.5s.

Dimming Curve

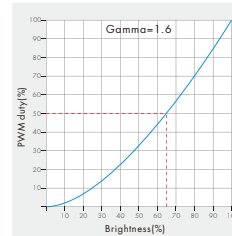

Malfunctions analysis & troubleshooting

Malfunctions	Causes	Troubleshooting
No light	1. No power. 2. Wrong connection or insecure.	1. Check the power. 2. Check the connection.
Uneven intensity between front and rear, with voltage drop	1. Output cable is too long. 2. Wire diameter is too small. 3. Overload beyond power supply capability. 4. Overload beyond controller capability.	1. Reduce cable or loop supply. 2. Change wider wire. 3. Replace higher power supply. 4. Add power repeater.
No response from the remote	1. The battery has no power. 2. Beyond controllable distance. 3. The controller did not match the remote.	1. Replace battery. 2. Reduce remote distance. 3. Re-match the remote.

Safety information

1. The product shall be installed and serviced by a qualified person.
2. The product is non-waterproof. Please avoid the sun and rain.
3. Good heat dissipation will prolong the working life of the controller. Please ensure good ventilation.
4. Please check if the output voltage of any power supplies used comply with the working voltage of the product.
5. Ensure all wire connections and polarities are correct and secure before applying power to avoid any damages to the LED lights.
6. If a fault occurs please return the product to your supplier. Do not attempt to fix this product by yourself.