

Single Color LED Controller

Model No.: V1-T

3-in-1 dimming/RF remote/0-10V/ Push Dim/20A output/Auto-transmitting/Synchronize

Features

- RF remote, 0/1-10V, Push Dim (3-in-1) dimming.
- 4096 levels 0-100% dimming smoothly without any flash.
- Match with RF 2.4G single zone or multiple zone dimming remote control.
- One RF controller accept up to 10 remote control.
- Auto-transmitting function: Controller automatically transmit signal to another controller with 15m control distance.
- Synchronize on multiple number of controllers.
- Connect with external push switch to achieve on/off and 0-100% dimming function.
- Light on/off fade time 3s selectable.
- Over-heat / Over-load / Short circuit protection, recover automatically.



FC CE RoHS EMC RED

Technical Parameters

Input and Output		Safety and EMC		Dimming data	
Input voltage	12-24VDC	EMC standard (EMC)	ETSI EN 301 489-1 V2.2.3	Input signal	RF 2.4GHz
Input current	20.5A		ETSI EN 301 489-17 V3.2.4		0/1-10V
Output voltage	12-24VDC	Safety standard(LVD)	EN 62368-1:2020+A11:2020	Control distance	15m(Barrier-free space)
Output current	1CH,20A	Radio Equipment(RED)	ETSI EN 300 328 V2.2.2	Dimming gray scale	4096 (2 ¹²) levels
Output power	240W/480W(12V/24V)	Certification	CE,EMC,LVD,RED	Dimming range	0-100%
Output type	Constant voltage	Package		Dimming curve	Logarithmic
Environment		Size	L120 x W80 x H34mm	PWM Frequency	2000Hz (default)
Operation temperature	Ta: -30 °C ~ +55 °C	Gross weight	0.254kg	Warranty	
Case temperature (Max.)	Tc: +85 °C			Warranty	5 years

Mechanical Structures and Installations

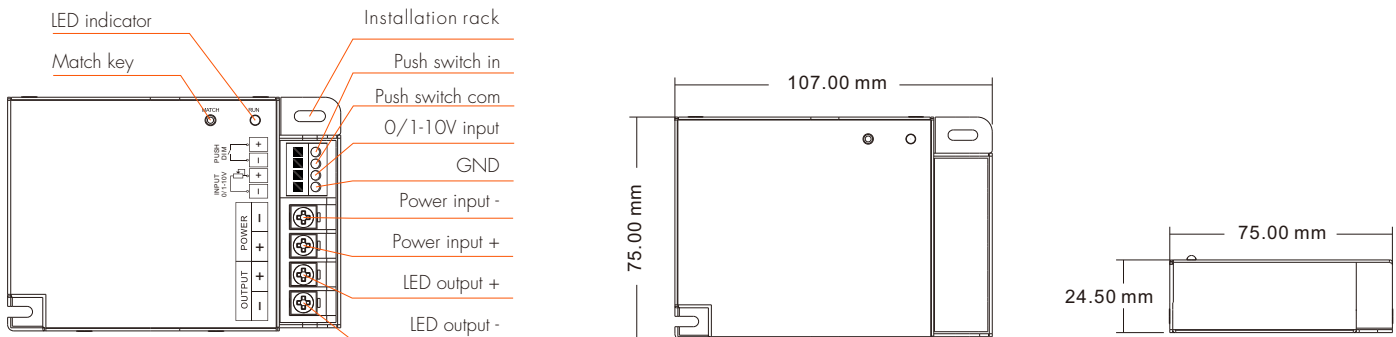

Match Remote Control (two match ways)

End user can choose the suitable match/delete ways. Two options are offered for selection:

Use the controller's Match key

Match:
Short press match key, immediately press on/off key (single zone remote) or zone key (multiple zone remote) of the remote.
The LED indicator fast flash a few times means match is successful.

Delete:
Press and hold match key for 5s to delete all match,
The LED indicator fast flash a few times means all matched remotes were deleted.

Use Power Restart

Match:
Switch off the power, then switch on power, repeat again.
Immediately short press on/off key (single zone remote) or zone key (multiple zone remote) 3 times quickly.
The light blinks 3 times means match is successful.

Delete:
Switch off the power, then switch on power, repeat again.
Immediately short press on/off key (single zone remote) or zone key (multiple zone remote) 5 times quickly.
The light blinks 5 times means all matched remotes were deleted.

Light on/off fade time

Long press match key 5s, then short press match key 3 times, the light on/off time will be set to 3s, the indicator light blink 3 times.

Long press match key 10s, restore factory default parameter, the light on/off time also restore to 0.5s.

Wiring Diagram

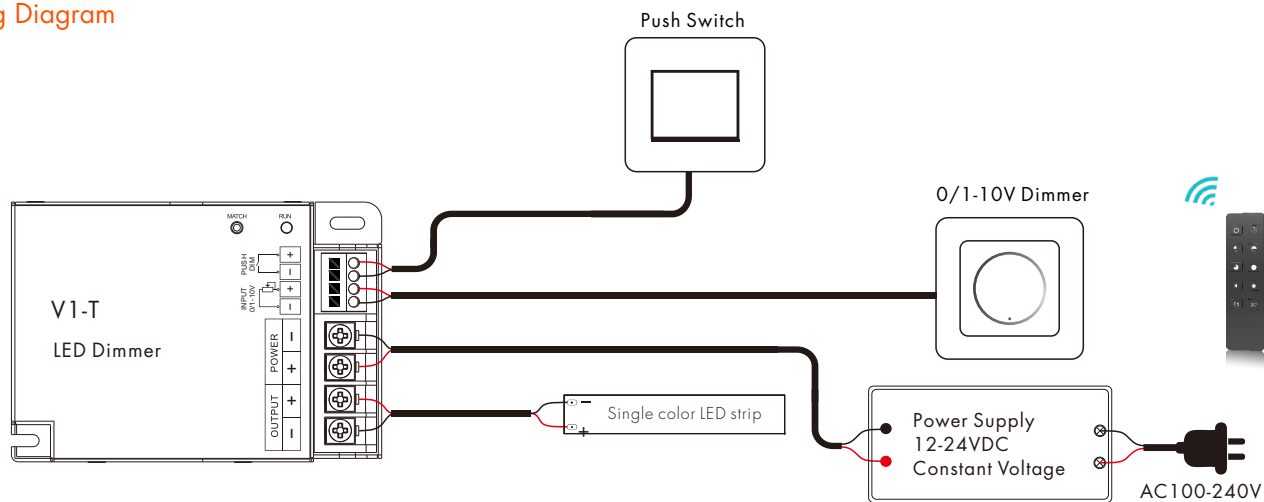

Note: The RF remote, O/1-10V dimmer or Push switch can be connected at the same time, which makes the product more user-friendly and more options to fit for some extra-ordinary demands.

O/1-10V Dimming

- The O/1-10V input is operable via commercially available simple rotary wall switches designed for O/1-10V dimming equipment or from dedicated system central dimming controllers.
- Compliant with 0-10V, 1-10V, 10V PWM, RX(4 in 1).
- We recommend the number of LED drivers connected to O/1-10V dimmer does not exceed 50 pieces, The maximum length of the wires from dimmer to LED driver should be no more than 50 meters.
- If the controller be used with the RF remote or Push-Dim interface prior to using the O/1-10 V signal, the O/1-10 V signal should change over 10% to return O/1-10 V control.

Push Dim Function

The provided Push-Dim interface allows for a simple dimming method using commercially available non-latching(momentary) wall switches.

- **Short press:**
Turn on or off light.
- **Long press (1-6s):**
Press and hold to step-less dimming, With every other long press, the light level goes to the opposite direction.
- **Dimming memory:**
Light returns to the previous dimming level when switched off and on again, even at power failure.
- **Synchronization:**
If more than one controller are connected to the same push switch, do a long press for more than 10s, then the system is synchronized and all lights in the group dim up to 100%.
This means there is no need for any additional synchrony wire in larger installations.
We recommend the number of controllers connected to a push switch does not exceed 25 pieces, The maximum length of the wires from push to controller should be no more than 20 meters.

Dimming Curve

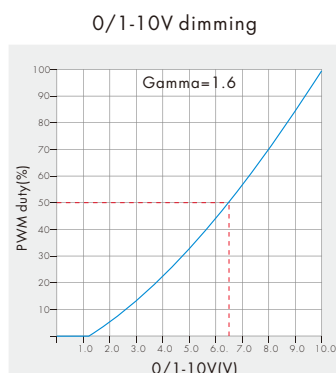
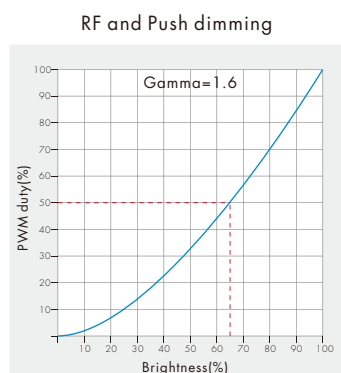

Installation Precautions

1. The products shall not be stacked, the distance should be $\geq 20\text{cm}$, so as not to affect lifespan of the products due to poor heat dissipation.
2. The product shall not be installed close to the switching power supply with an interval of $\geq 20\text{cm}$ to avoid the radiation interference of the switching power supply.
3. The installation height shall be $\geq 1\text{m}$ from the floor to avoid shortening the remote control distance due to too weak reception signal.
4. The products are not allowed to be close to or covered by metal objects, with an interval of $\geq 20\text{cm}$ to avoid signal attenuation and shorten the remote control distance.
5. Avoid installation at the corner of the wall or the corner of the beam, with an interval of $\geq 20\text{cm}$ to avoid signal interference.

Malfunctions Analysis & Troubleshooting

Malfunctions	Causes	Troubleshooting
No light	<ol style="list-style-type: none"> 1. No power. 2. Wrong connection or insecure. 	<ol style="list-style-type: none"> 1. Check the power. 2. Check the connection.
Uneven intensity between front and rear, with voltage drop	<ol style="list-style-type: none"> 1. Output cable is too long. 2. Wire diameter is too small. 3. Overload beyond power supply capability. 4. Overload beyond controller capability. 	<ol style="list-style-type: none"> 1. Reduce cable or loop supply. 2. Change wider wire. 3. Replace higher power supply. 4. Add power repeater.
No response from the remote	<ol style="list-style-type: none"> 1. The battery has no power. 2. Beyond controllable distance. 3. The controller did not match the remote. 	<ol style="list-style-type: none"> 1. Replace battery. 2. Reduce remote distance. 3. Re-match the remote.