

Dual PIR Sensor + Dual Push Button SPI Controller

- Dual PIR sensor + dual push button input RGB or white light SPI controller features daylight sensor.
- Two groups same SPI(TTL) signal output, drive 28 kinds IC digital RGB or white LED strip, IC type and R/G/B order can be set.

Compatible ICs:

TM1804, TM1809, TM1812, UCS1903, UCS1909, UCS1912, UCS2903, UCS2909, UCS2912, WS2811, WS2812, TM1829, TM1914A, GW6205, GS8206, GS8208, LPD6803, LPD1101, D705, UCS6909, UCS6912, LPD8803, LPD8806, WS2801, WS2803, P9813, SK9822, SM16703P.

- When applied to stair light, supports four output modes: color flow, white flow, color step, white step.
- Sequential switching control is realized when multiple SPI controllers are connected to a single self-resetting push switch button.
- Multiple light colors and change types are selectable with adjustable speed and brightness.

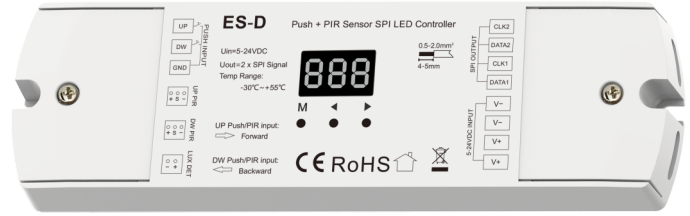

Technical Parameters

Input and Output		Sensor data		Safety and EMC	
Input voltage	5-24VDC	Sensitive field	≤3m	EMC standard (EMC)	ETSI EN 301 489-1 V2.2.3 ETSI EN 301 489-17 V3.2.4
Input current	8A	Sensitivity angle	30°(±10°)	Safety standard	EN 62368-1:2020+A1 1:2020
Output signal	2 X SPI(TTL)	Environment		Certification	CE, EMC
Pixel number	Max 960	Operation temperature	Ta: -30°C ~ +55°C	Package	
Input signal	PIR sensor + Push button	Case temperature (Max.)	Tc: +65°C	Size	L175 x W120 x H35mm
Warranty		IP rating	IP20	Gross weight	0.27kg
Warranty	5 years				

Mechanical Structures and Installations

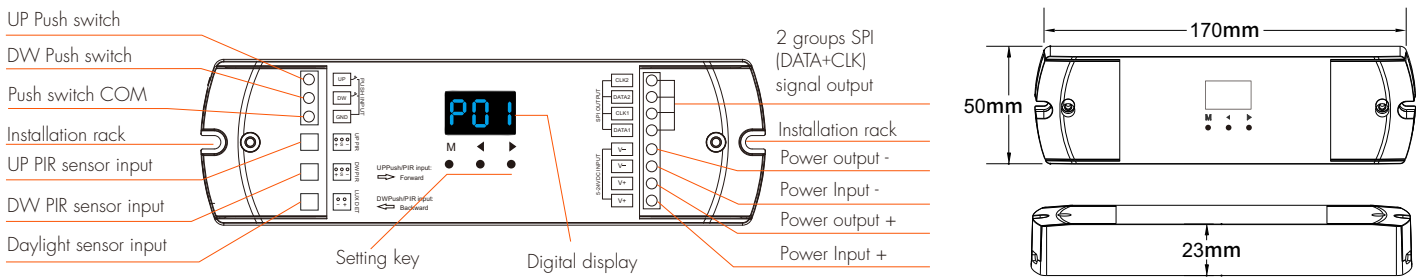

Wiring Diagram

1. Stair light application, connect with PIR sensor, color or white light flow control

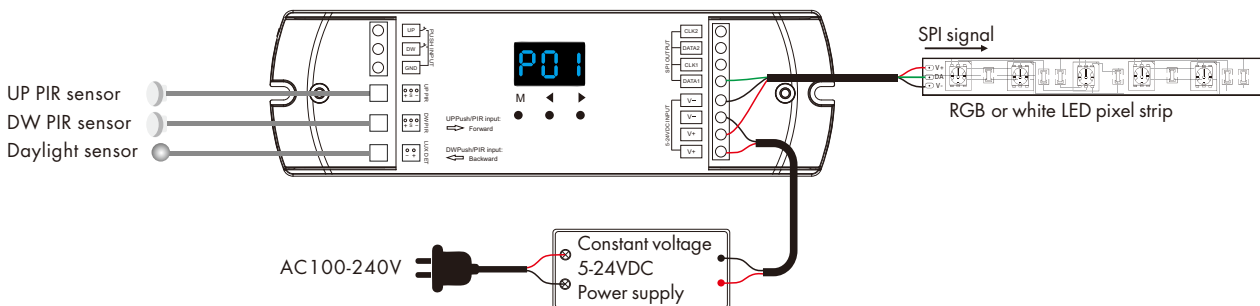

2. Stair light application, connect with PIR sensor, color or white light step control

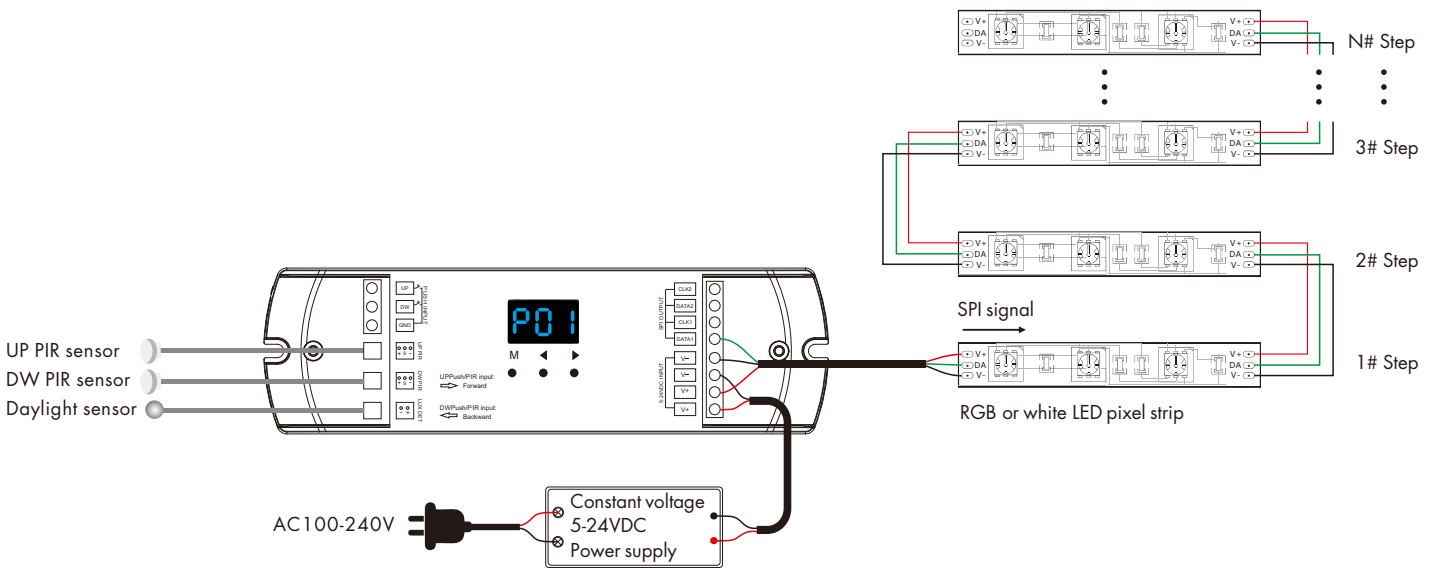

3. One push switch connect with multiple controllers for sequential switching control

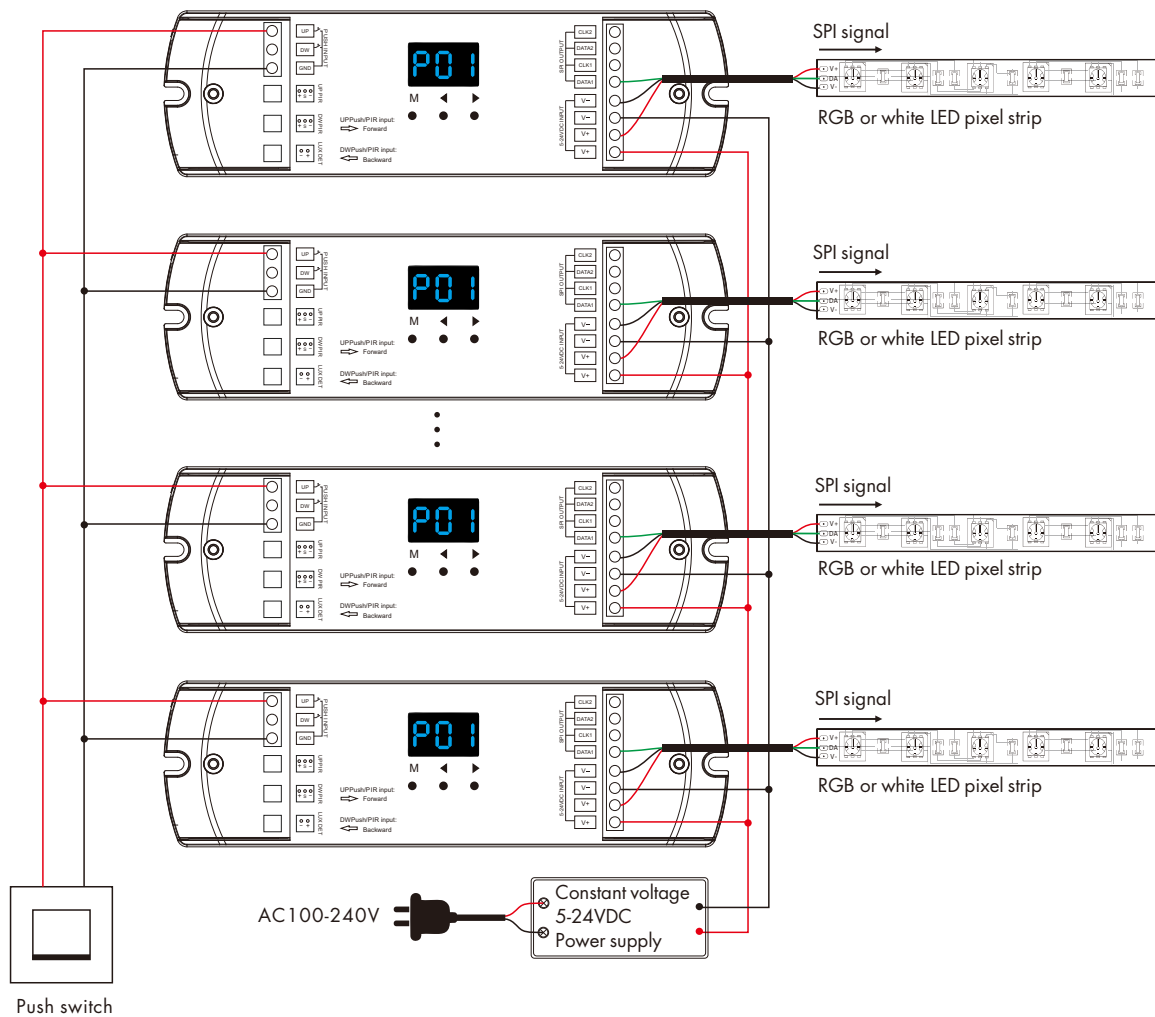

- Note:**
1. If the SPI LED strip is a single-wire control method, the DATA and CLK signal line outputs of the controller are same, and one controller can connect four LED strips.
 2. If the SPI LED strip is a dual wire control method, one controller can connect two LED strips.
 3. When the SPI strip load does not exceed 15A, the same power supply can simultaneously power the ES-D controller and the SPI strip at the same time.
When the load on the SPI strip exceeds 15A, separate power supplies are required for the ES-D controller and the SPI strip.
Only DATA and GND signal lines are connected between ES-D controller and SPI strip.
 4. The PIR sensor can be replaced with a stair infrared reflection sensor(ES-T) or other sensors that output 5V level signals.
 5. The color or white light flow model can control up to 960 pixel points of SPI strip.
 6. The color or white light step model defaults to 30 steps with 10 pixels per step. the step number x pixel length per step must ≤ 960 .

System Parameters Setting

- Press and hold the M and ◀ key for 2s simultaneously, enter the system parameters setting state: set the light type, LED strip connection method (flow or step) pixel point number, step number, light on/off mode, turn off light delay time, daylight detection, push switch to turn on or off the light delay time.
- Press and hold the M and ▶ key for 2s simultaneously, enter the LED light strip parameters setting state: set the chip type, RGB color order.
- In the parameter setting state, short press M key to switch multiple parameter items, press ◀ or ▶ key to adjust the parameter value of each parameter item.
- Press and hold the M key for 2s or wait for 1.5s, quit the parameter setting state.
- Long press ◀ and ▶ key for 2s simultaneously, restore factory default parameters, display "RES". Factory default parameters: RGB color light flow output, 300 pixels, sequential light on, sequential light off, 30s delay off time, disable daylight detection, push switch turn on delay and turn off delay is 0s, chip type TM1809, RGB order.

Light type: Set three light types.

3-bead white light: 1 pixel with 3 same data, control 3-bead white LED, display "L-1".

1-bead white light: 1 pixel with 1 data, control 1-bead white LED, display "L-2".

RGB color light: 1 pixel with 3 data, control one R/G/B LED, display "L-3".

Output mode: Set up flow or step output.

Flow: Straight line digital pixel LED strip light mode, display "o-L".

Step: Z-shape digital pixel LED strip light mode, display "o-S".

Pixel dots: For color or white flow mode, set the number of pixel points, the range is 032-960, display "032"- "960".

Step numbers: For color or white step mode, set the number of steps and pixel dot number of each step.

Step number: the range is 8-99, display "S08"- "S99";

Pixel dot number of each step: the range is 2-99, display "L02"- "L99".

the step number x pixel dot number of each step number must \leq 960.

Light on mode: Set how the light turn on when the sensor activated and self-reset button turn on the light.

Sequential light on: Light turn on sequentially from the beginning to the end, display "onS".

Synchronized light on: Light turn on synchronously, display "onC".

Light off mode: Set how the light turn off when sensing ends and when the self-reset button turn off the light.

Sequential light off: Light turn off sequentially from the beginning to the end, display "oFS".

Sequence light off in reverse: Light turn off sequentially from end to beginning, display "oFb".

Synchronized light off: Light turn off synchronously, display "oFC".

List of ways to turn on/off light combinations:

Display	Name
onS + oFS	Sequential light on, sequential light off
onS + oFb	Sequential light on, sequential reverse light off
onS + oFC	Sequential light on, synchronized light off
onC + oFS	Synchronized light on, sequential light off
onC + oFb	Synchronized light on, sequential reverse light off
onC + oFC	Synchronized light on, synchronized light off

Sensor light off delay: Set the time delay for turning off the light at the end of sensing:

5sec (d05), 10sec (d10), 30sec (d30), 1min (01d), 3min (03d), 5min (05d), 10min (10d), 30min (30d), 60min (60d), cancel (d00),

Set cancel means not turn off the light.

LUX detection: Set the daylight detection on "Lon" or off "LoF". When daylight detection is on, PIR sensing turn on light only when the ambient light is low.

Self-reset push switch turn on light delay time: Setting range 0-15.5s, the smallest unit 0.5s, display "o00"- "o95"- "oF5", A-F indicates that 10-15s.

Setting 0s means turn on light immediately.

Self-reset push switch turn off light delay time: Setting range 0-15.5s, the smallest unit 0.5s, display "o00"- "o95"- "oF5", A-F indicates that 10-15s.

Setting 0s means turn off light immediately.

Chip type: Select the chip type of the LED strip (shown in below table), display "C11"- "C25".

RGB color order: Select 6 RGB orders (RGB, RBG, GRB, GBR, BRG, BGR), display "0-1" - "0-6" respectively.

LED strip IC types list:

No.	IC type	Compatible IC type	Output signal
C11	TM1809	TM1804, TM1812, UCS1903, UCS1909, UCS1912, UCS2903, UCS2909, UCS2912, WS2811, WS2812, SM16703P	DATA
C12	TM1829		DATA
C13	TM1914A		DATA
C14	GW6205		DATA
C15	GS8206	GS8208	DATA
C21	LPD6803	LPD1101, D705, UCS6909, UCS6912	DATA, CLK
C22	LPD8803	LPD8806	DATA, CLK
C23	WS2801	WS2803	DATA, CLK
C24	P9813		DATA, CLK
C25	SK9822		DATA, CLK

Light effect settings

1. Color Flow/Color Step Mode



- The digital tube display "P01"-"P95", the 2nd digit indicates the light color, the 3rd digit indicates the type of light change.
- Short press ◀ key to switch 10 light colors in sequence, the 2nd digit shows 0-9. The 0th color light color can be customized, the 1st-7th color light is single color, the 8th-9th color light is multi-color.
- Short press ▶ key to switch 5 light change types in sequence, the 3rd digit shows 1-5.
- The light color and light change type are combined to form 50 kinds of light effects, each light effect can be adjusted in speed and brightness.
- Long press M key for 2s to enter the light effect parameter setting state, set speed, brightness, self-defined R/G/B color.
- Short press M key to switch multiple parameter items, press ◀ or ▶ key to adjust the parameter value of each parameter item. Speed: 1-8 levels adjustable, display "S-1"-"S-8", S-8 is the maximum speed. Brightness: 1-10 level adjustable, display "b10"-"bFF", bFF means maximum brightness 100%. Self-defined R/G/B color: 0-255 (00-FF) adjustable. R channel displays "100"-"1FF"; G channel displays "200"-"2FF"; B channel displays "300"-"3FF".
- Press and hold M key for 2s or wait for 15s, quit the light effect parameter setting.

Color type (2nd digit):

NO.	Name
0	Rxxx Gxxx Bxxx (User define)
1	Red
2	Orange
3	Yellow
4	Green
5	Cyan
6	Blue
7	Purple
8	R/G/B 3 color
9	7 color

Color/white light change type (3rd digit):

NO.	Name
1	Flow
2	Chase
3	Float
4	Trail
5	Trail+black section

2. White Flow/White Step Mode



- The digital tube display "P-1"-"P-5", the 3rd digit indicates the type of light change.
- Short press ◀ or ▶ key to switch 5 light change types in sequence, the 3rd digit shows 1-5.
- Each lighting effect can be adjusted for speed and brightness.
- Long press M key for 2s to enter the light effect parameter setting state, set speed, brightness. Short press M key to switch multiple parameter items, press ◀ or ▶ key to adjust the parameter value of each parameter item. Speed: 1-8 levels adjustable, display "S-1"-"S-8", S-8 is the maximum speed. Brightness: 1-10 level adjustable, display "b10"-"bFF", bFF means maximum brightness 100%.
- Long press M key for 2s or wait for 15s, quit the light effect parameter setting.

Typical application

1. Dual PIR sensing control

- Connect two PIR sensors to realize automatic staircase light control.
- The UP PIR sensor is installed at the bottom of the staircase, when sensing a person, the digital tube instantly displays "u", the light is automatically turned on, and the light is turned off with a delay.
- The DW PIR sensor is installed at the top of the staircase, when sensing a person, the digital tube instantly displays "d", the light is automatically turned on, and the light is turned off with a delay.
- If you set the daylight sensor detection on, the light will be turned on only in darker environment or at night.

2. Dual self-reset push switch manual control

- Connect two push switches for manual staircase light control.
- The UP push switch is installed at the bottom of the stairs; the DW push switch is installed at the top of the stairs.
- Set the self-reset push switch to 0s for both light on delay and light off delay.
short press the self push switch to turn on the light, display the current light effect mode;
short press the self push switch again, turn off the light, display "OFF".
Long press the UP self-reset push switch to adjust the brightness, range 10-100%, display "b10"- "bFF".
(Note: The DW self-reset push switch does not have the function of adjusting the brightness.)

Note: Using self-reset push switch control will ignore the daylight sense detection.

3. Self-reset push switch connect multiple controllers for sequential switching control

- Multiple controllers are connected to onepush switche at the same time to realize sequential switching control.
- Set the self-reset push switch on delay and off delay to incremental or decremental values for multiple controllers. for example: set 1-4# controllers' light on delay to 0s, 1s, 2s, 3s respectively, and light off delay to 3s, 2s, 1s, 0s respectively. In this way, 1-4# controllers will turn the lights on in the same sequence and off in the reverse sequence.
- Short press the self-reset push switch to turn on the lights sequentially, digital display "don" during the delayed light on time. When the light on, display the current light effect mode.
- Short press the self-reset push switch again to turn off the lights sequentially, digital display "doF" during the delayed light off time. When the light off, display "OFF".

Note: When the lighting effects of multiple controllers are confused, they can be quickly restored by double-clicking the self-reset push switch.

Installation of PIR sensor

Size of detector:

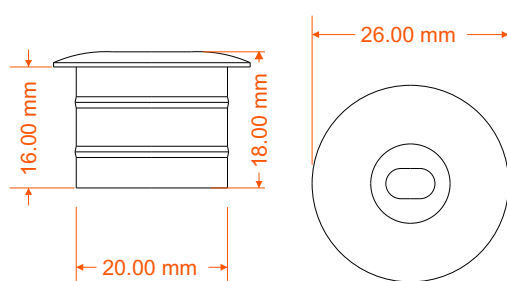

PIR sensor detection scope ($\pm 10^\circ$ Error):

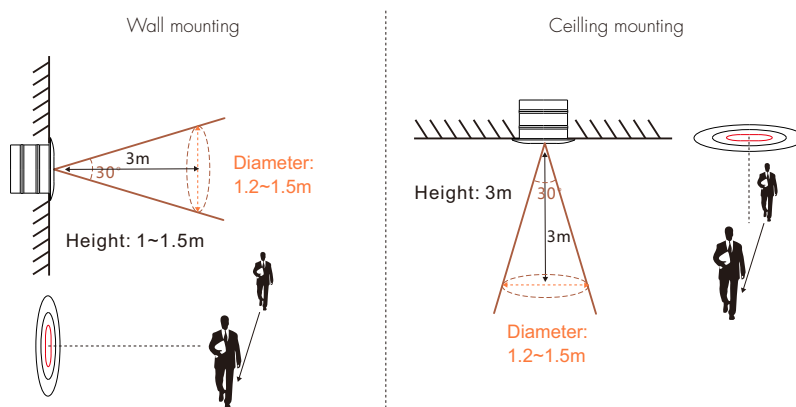

Notice for installation of PIR sensor

1. Recommended for wall mounting.
2. If the sensor is exposed to direct sunlight, interference signal will be introduced.
3. The sensor should be installed in a dry environment and keep away from windows, air conditioner and fans.
4. Make sure that the sensor stays away from heat source, such as countertops, kitchen appliances which generate hot steam, walls and windows in direct sunlight, air conditioner, heating, refrigerators, stoves and so on.
5. We recommended the wall-mounted installation height is 1.1~1.5 meters and the ceiling mounting height is no more than 3 meters.
6. There should not be shelter(screen, furniture, large bonsai) within the range of detection.

★ For wall mounting and ceiling mounting, note that the sensing holes are perpendicular to the direction of human movement.

Packing List



LED Controller
1 pcs



User Manual
1 pcs



Daylight sensor (30cm)
1 pcs



PIR sensor
2 pcs



PIR sensor extension line (5m)
2 pcs