

24 Channel Constant Voltage DMX512 & RDM Decoder / Master

- 24 channels constant voltage output, Max. 4A current per channel, up to 2304W output power.
- Master & decoder mode, RDM function.
- Easy operation with OLED display and 4 buttons.
- DIM/CCT/RGB/RGBW decoding mode selectable.
- PWM frequency 500/2000/8000/16000Hz selectable.
- 16bit (65536 levels) / 8bit (256 levels) grey level selectable.
- Output dimming curve gamma value 0.1-9.9 selectable.
- Stand-alone RGBW mode and 24 channel dimmer mode selectable, work as DMX master(8 bit) to control other decoders.
- Built-in 10 RGBW programs, speed and brightness adjustable.
- Comply with the DMX512 standard protocols.
- DMX signal optoelectronic isolation / amplify.
- Over-heat / Overload / Short circuit protection, recover automatically.
- With fast self-testing function.

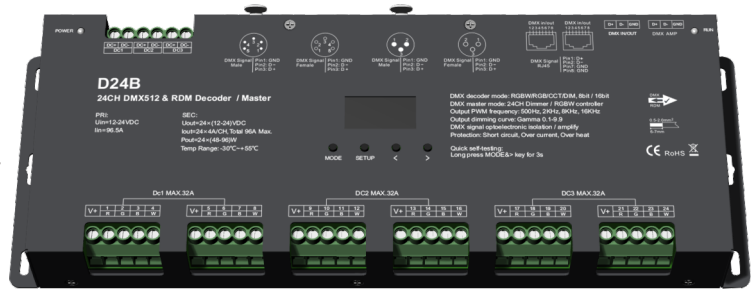

CE RoHS LVD

Technical Parameters

Input and Output		Environment		Safety and EMC	
Input voltage	12-24VDC	Operation temperature	Ta: -30°C ~ +55°C	EMC standard (EMC)	EN55032:2015, EN61000-3-2:2014, EN61000-3-2:2013, EN55024 :2010/A1:2015
Input current	96.5A	Case temperature (Max.)	Tc: +85°C		
Output voltage	24 x (12-24)VDC	IP rating	IP20	Safety standard(LVD)	EN 61347-1:2015 EN 61347-2-11:2015
Output current	24CH, 4A/CH	Package			
Output power	24 x (48-96)W	Size	L335 x W135 x H46mm	Certification	CE,EMC,LVD
Output type	Constant voltage	Gross weight	0.123kg	Warranty	
				Warranty	5 years

Mechanical Structures and Installations

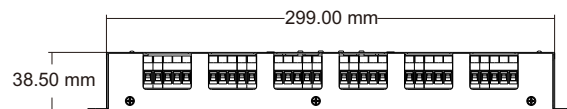
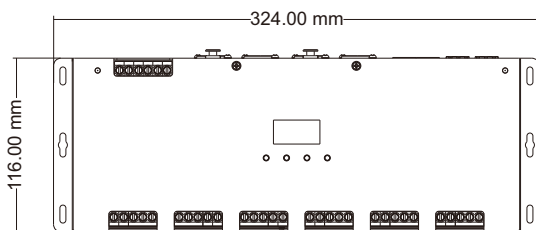

Wiring Diagram

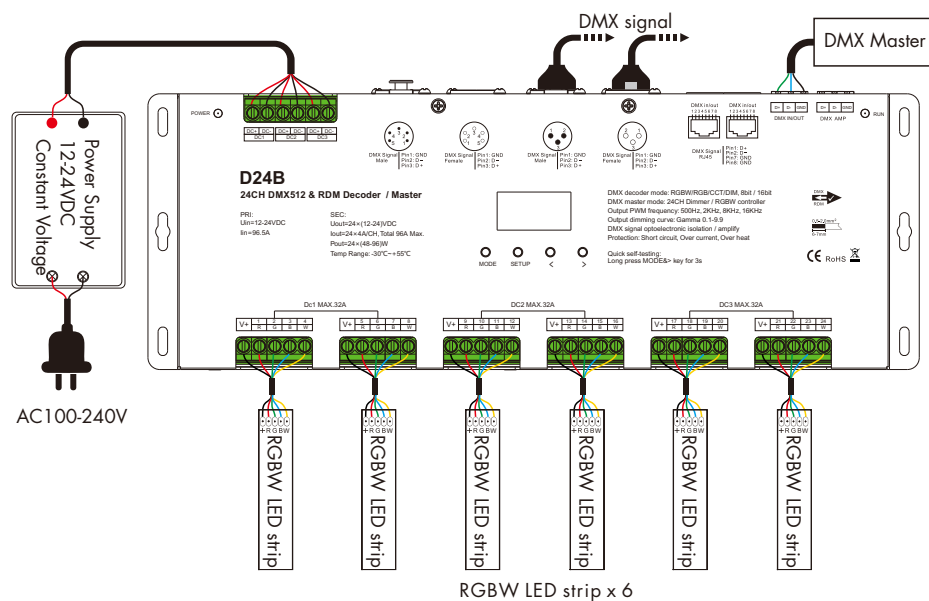

Note:

1. Connecting with green terminal (DMX AMP) or an extra amplifier will be needed when more than 32 decoders are connected, or use overlong signal line, signal amplification should not be more than 5 times continuously.
2. If the recoil effect occurs because of longer signal line or bad line quality, please try to connect 0.25W 90-120Ω terminal resistor at the end of each DMX signal line.
3. When the 24-way load is too large and the input power of one constant voltage power supply is insufficient, multiple constant voltage power supplies can be used. Up to 3 constant voltage power supplies can be connected as power inputs, each power supply can be used to supply 6 loads respectively.

OLED screen interface



Short press MODE key, switch between DMX decoder mode, Dimmer mode and RGBW controller mode.
 Short press SETUP key, enter parameter setting state, and switch between multiple parameter item.
 press < or > key for parameter adjustment.
 long press SETUP key or wait 10s to quit parameter setting state.
 Long press M & > key for 2s, enter fast self-testing.
 Long press < & > key for 2s, restore factory default parameter.

DMX decoder mode



DMX decode start address: 001~512
 DMX decode mode: **DIM** (1CH single color) **CCT** (2CH color temperature)
RGB (3CH) **RGBW** (4CH)

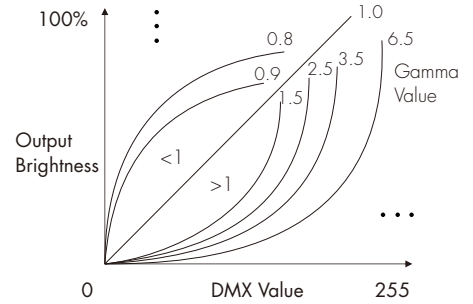

Output PWM frequency:

Std (2KHz)
High (8KHz) Higher PWM frequency, will cause lower output current, higher power noise,
Mid (500Hz) but more suitable for camera(No flickers for video).
Supr (16KHz)

Grey level:

8bit
16bit (choose it if the DMX master support 16 bit)

Output dimming curve(Only valid for 8bit Grey level):

Standard (Gamma 1.6)

Linear

Gamma0.1-9.9

It is recommended to use standard,
 0.1-9.9 is for special requirements, long press < or > key to change 0.1-9.9.

DMX master mode as 24 channel dimmer



Each channel brightness setting: Range: 0-255 (0-100%)
 <<&>>: press < or > key to switch between previous or next page, each page 4 channel.

DMX master mode as RGBW controller

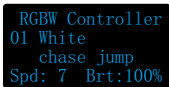

Dynamic RGBW mode: 10 kinds
 Mode speed: 1-10 level, Level 10 fastest speed
 Mode brightness: 10%-100%

Dynamic RGBW mode list:

No.	Name
01	White chase jump
02	White synchronous fade
03	White chase fade
04	Color synchronous jump (Red, Yellow, Green, Cyan, Blue, Purple)
05	Color chase jump (Red, Yellow, Green, Cyan, Blue, Purple)
06	Color synchronous gradual
07	Color jump gradual
08	R/G/B/W synchronous fade
09	R/G/B/W chase fade
10	All mode loop play

Address setting table

8bit:

Mode	DIM	CCT	RGB	RGBW	
Address Quantity	6	12	18	24	
Channel	1	001	001	001	001
	2	001	002	002	002
	3	001	001	003	003
	4	001	002	003	004
	5	002	003	004	005
	6	002	004	005	006
	7	002	003	006	007
	8	002	004	006	008
	9	003	005	007	009
	10	003	006	008	010
	11	003	005	009	011
	12	003	006	009	012
	13	004	007	010	013
	14	004	008	011	014
	15	004	007	012	015
	16	004	008	012	016
	17	005	009	013	017
	18	005	010	014	018
	19	005	009	015	019
	20	005	010	015	020
	21	006	011	016	021
	22	006	012	017	022
	23	006	011	018	023
	24	006	012	018	024

16bit:

Mode	DIM	CCT	RGB	RGBW	
Address Quantity	12	24	36	48	
Channel	1	001 002	001 002	001 002	001 002
	2	001 002	003 004	003 004	003 004
	3	001 002	001 002	005 006	005 006
	4	001 002	003 004	005 006	007 008
	5	003 004	005 006	007 008	009 010
	6	003 004	007 008	009 010	011 012
	7	003 004	005 006	011 012	013 014
	8	003 004	007 008	011 012	015 016
	9	005 006	009 010	013 014	017 018
	10	005 006	011 012	015 016	019 020
	11	005 006	009 010	017 018	021 022
	12	005 006	011 012	017 018	023 024
	13	007 008	013 014	019 020	025 026
	14	007 008	015 016	021 022	027 028
	15	007 008	013 014	023 024	029 030
	16	007 008	015 016	023 024	031 032
	17	009 010	017 018	025 026	033 034
	18	009 010	019 020	027 028	035 036
	19	009 010	017 018	029 030	037 038
	20	009 010	019 020	029 030	039 040
	21	011 012	021 022	031 032	041 042
	22	011 012	023 024	033 034	043 044
	23	011 012	021 022	035 036	045 046
	24	011 012	023 024	035 036	047 048

Note: even channel for micro dimming.