

# 12 Channel Constant Voltage DMX512 & RDM Decoder / Master

Model No.: D12A

RDM/Stand-alone function/8 bit or 16bit decode/Four PWM frequency/Multiple dimming curve/OLED display

## Features

- 12 channels constant voltage output, Max. 5A current per channel, up to 1440W output power.
- Master & decoder mode, RDM function.
- Easy operation with OLED display and 4 buttons.
- DIM/CCT/RGB decoding mode selectable.
- PWM frequency 250/500/2000/8000Hz selectable.
- 16bit (65536 levels) /8bit (256 levels) grey level selectable.
- Output dimming curve gamma value 0.1-9.9 selectable.
- Stand-alone RGB mode and 12 channel dimmer mode selectable, work as DMX master(8 bit) to control other decoders.
- Built-in 10 RGB programs, speed and brightness adjustable.
- Comply with the DMX512 standard protocols.
- DMX signal optoelectronic isolation / amplify.
- Over-heat / Over-load / Short circuit protection, recover automatically.
- With fast self-testing function.



## Technical Parameters

Input and Output	
Input voltage	12-24VDC
Input current	60.5A
Output voltage	12 x (12-24)VDC
Output current	12CH,5A/CH
Output power	12 x (60-120)W
Output type	Constant voltage

Environment	
Operation temperature	Ta: -30°C ~ +55°C
Case temperature (Max.)	Tc: +85°C
IP rating	IP20

Safety and EMC	
EMC standard (EMC)	EN55032:2015, EN61000-3-2:2014, EN61000-3-2:2013, EN55024 :2010/A1:2015
Safety standard(LVD)	EN 61347-1:2015 EN 61347-2-11:2015
Certification	CE,EMC,LVD

Warranty and Protection	
Warranty	5 years
Protection	Reverse polarity Over-heat Over-load Short circuit

## Mechanical Structures and Installations

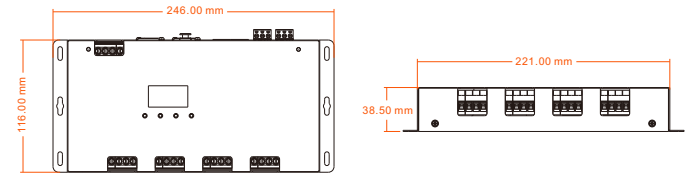

## Wiring Diagram

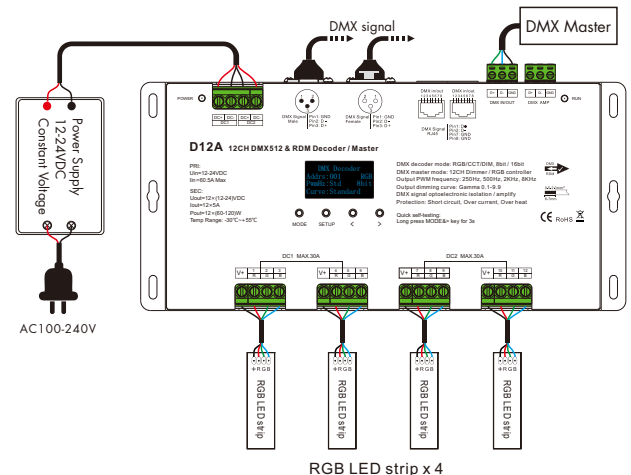

Note:

1. Connecting with green terminal (DMX AMP) or an extra amplifier will be needed when more than 32 decoders are connected, or use overlong signal line, signal amplification should not be more than 5 times continuously.
2. If the recoil effect occurs because of longer signal line or bad line quality, please try to connect 0.25W 90-120Ω terminal resistor at the end of each DMX signal line.

## OLED screen interface



Short press MODE key, switch between DMX decoder mode, Dimmer mode and RGB controller mode.  
 Short press SETUP key, enter parameter setting state, and switch between multiple parameter item.  
 press < or > key for parameter adjustment.  
 long press SETUP key or wait 30s to quit parameter setting state.  
 Long press M & > key for 2s, enter fast self-testing.  
 Long press < & > key for 2s, restore factory default parameter.

### DMX decoder mode



DMX decode start address:  
 Range: 001~999

DMX decode mode:  
 DIM (1CH single color) CCT (2CH color temperature) RGB (3CH)

#### Output PWM frequency:

Std (2KHz)  
 High (8KHz) Higher PWM frequency, will cause lower output current,  
 Mid (500Hz) higher power noise, but more suitable for camera(No flickers for video).  
 Low (250Hz)

#### Grey level:

8bit  
 16bit (choose it if the DMX master support 16 bit)

#### Output dimming curve(Only valid for 8bit Grey level):

Standard (Gamma 1.6)  
 Linear  
 Gamma0.1-9.9

It is recommended to use standard,  
 0.1-9.9 is for special requirements.

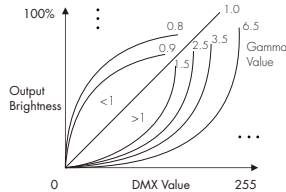

### DMX master mode as 12 channel dimmer



Each channel brightness setting:  
 Range: 0-255

<<&>>:  
 press < or > key to switch between previous or next page, each page 3 channel.

### DMX master mode as RGB controller

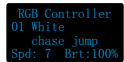

Dynamic RGB mode list:

No.	Name
01	White chase jump
02	White synchronous fade
03	White chase fade
04	R/G/B/W synchronous jump
05	R/G/B/W chase jump
06	Color synchronous gradual
07	Color jump gradual
08	R/G/B/W synchronous fade
09	R/G/B/W chase fade
10	All mode loop play

Dynamic RGB mode:  
 10 kinds

Mode speed:  
 Range: 1-10 level

Mode brightness:  
 Range: 10%-100%

## Address setting table

### 8bit:

Mode	DIM	CCT	RGB
Address Quantity	4	8	12
Channel	1	001	001 001
	2	001	002 002
	3	001	002 003
	4	002	003 004
	5	002	004 005
	6	002	004 006
	7	003	005 007
	8	003	006 008
	9	003	006 009
	10	004	007 010
	11	004	008 011
	12	004	008 012

### 16bit:

Mode	DIM	CCT	RGB
Address Quantity	8	16	24
Channel	1	001 002	001 002 001 002
	2	001 002	003 004 003 004
	3	001 002	003 004 005 006
	4	003 004	005 006 007 008
	5	003 004	007 008 009 010
	6	003 004	007 008 011 012
	7	005 006	009 010 013 014
	8	005 006	011 012 015 016
	9	005 006	011 012 017 018
	10	007 008	013 014 019 020
	11	007 008	015 016 021 022
	12	007 008	015 016 023 024

Note: even channel for micro dimming.

## Malfunctions analysis & troubleshooting

Malfunctions	Causes	Troubleshooting
No light	1. No power. 2. Wrong connection or insecure.	1. Check the power. 2. Check the connection.
Wrong color	1. Wrong connection of R/G/B wires. 2. DMX decode address error.	1. Reconnect R/G/B wires. 2. Set correct decode address.
Uneven intensity between front and rear,with voltage drop	1. Output cable is too long. 2. Wire diameter is too small. 3. Overload beyond power supply capability. 4. Overload beyond controller capability.	1. Reduce cable or loop supply. 2. Change wider wire. 3. Replace higher power supply. 4. Add power repeater.